

LM3X

L A Z 3

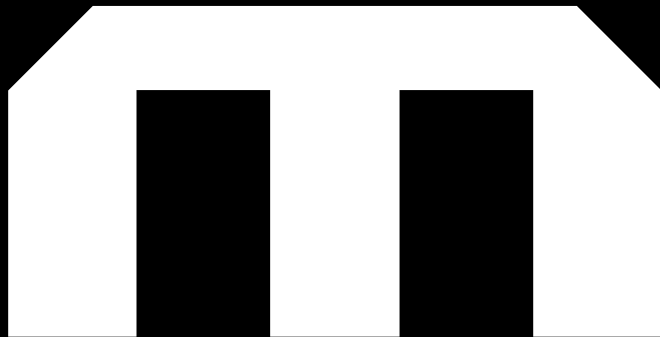

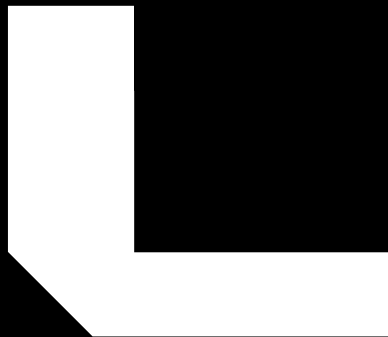

Find the complete manual online



<https://lm3x.guide/>

Device type

L A Z R



Necessary settings



The device uses all remote sensors for its correct operation.
Never turn off the remote sensors in the projector menu!
Always keep the Remote Sensor value at All in the Advanced menu of the projector.

How to use the remote control and using the projector's menu, can be found in the user guide of the ViewSonic LS900WU at the internet address:

<https://www.viewsonic.com/eu/products/projectors/LS900WU#downloads>

Failure to read and follow the below specified instructions may result in fire, personal injury, or damage to property!



Front & Back Panel



1 Power socket

2 Power button

3 Status LED indicator

4 Power ON indicator

5 Beamer lens

6 Air filter cover

7 PjLink / HDBaseT / Lan socket



Correct Outdoor Positioning

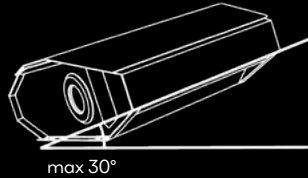
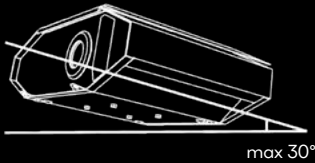
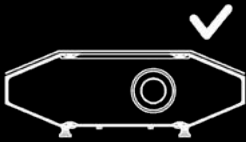



Technical Data

Input voltage	110 - 230 V ~ 50/60 Hz
Power consumption (max.)	550 W
Standby power consumption(typ.)	30W
Operating temperature (typ.)	-20° ~ +40 °C
Ingress protection	IP43
Overvoltage protection	power supply, LAN
Dimensions (HxWxL)	237 x 538 x 672 mm
Weight	23 kg
Display type	LASER DLP
Brightness	6.000 ANSI/lm
Laser lifespan	20.000 h
Native resolution (px)	1920x1200 (WUXGA)
Aspect ratio	16:10
Throw ratio (lens)	1.2 - 1.9
Control / data input	PJLink™, USB 3.0, LAN
Video input	HDMI™, HDBaseT™
Wireless control	IR controller
Shielding	grounded to the chasis
Power supply for your AV/computer system	USB DC 5V 3A, DC 12V 10A



Important Safety Instructions

- Failure to read and follow the below specified instructions may result in fire, personal injury, or damage to property!
- No leaking objects may be placed above the device.
- Do not open the cover if the weather or rain is bad.
- Always pay extra attention when handling and installing the device. There is a risk of equipment components falling and causing injury or property damage.
- This device contains a non-rechargeable lithium battery.
- Do not cover device while it is running.
- Only well-mounted control units / computers may be placed in the device.
- The unit must not be exposed to very strong splashing water.
- The device must be grounded via a grounded power cable using a grounded cable and the device grounding point.
- Always use the device in an electrical circuit that is protected against short circuit by a 16A circuit breaker with B or C characteristic.
- Installation of the equipment should be supervised by an expert, who will also verify the correct connection grounding and appropriate IP protection of the components outside the device.
- Protect the power cord from being stepped on or pinched particularly at plugs. Be sure that the power outlet is located near the unit so that it is easily accessible.
- Use only with a cart, stand, tripod, bracket, or table specified by the manufacturer or sold with the unit. When a cart is used, use caution when moving the cart/unit combination to avoid injury from tipping over.
- Unplug this unit when unused for long periods of time.
- Refer all servicing to qualified service personnel. Servicing is required when the unit has been damaged in any way, such as: if power plug is damaged, if liquid is spilled onto or objects fall into the unit, or if the unit does not operate normally or has been dropped.
- Do not place this projector on a blanket, bedding, or any other soft surface.
- Do not cover this projector with a cloth or any other item.
- Do not place inflammables near the projector.
- Do not place this projector in locations near fire alarms.
- Do not place this projector in a space that is poorly ventilated or confined. Allow at least 50 cm clearance from walls and free flow of air around the projector.



Device Description

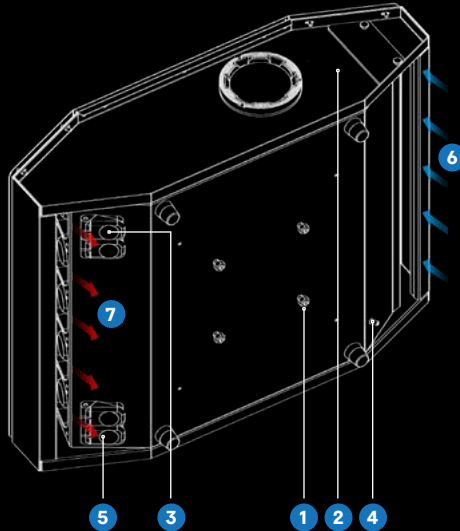

- 1 Fixture attachment points x 4
- 2 Space for WiFi USB module (inside the device)
- 3 USB connector
- 4 Grounding point
- 5 HDMI connector
- 6 Air intake
- 7 Air exhaust



Attachment System

Your LAZR series projector is supplied with an attachment system (optional). There are two interchangeable mounts, one for the wall and one for the post installation. Make sure that you use a sufficient fixture and always think **SAFETY FIRST!**

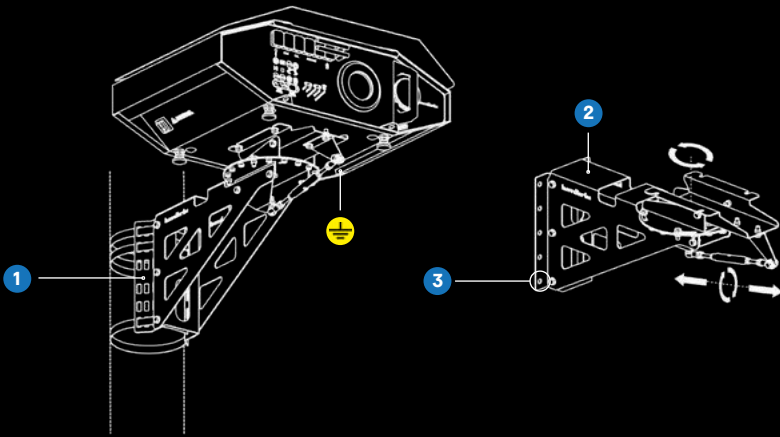

- 1 Post Fixture Mount
- 2 Wall Fixture Mount
- 3 Use Screw M8x16 / 16 Nm (x 6)

 Always use sufficient grounding protection attached to the grounding screw



Safety Instructions

- The LAZR projector is weather protected (IP43) and can operate outdoors within a operating temperature range of $-20^{\circ}\text{C} < > +40^{\circ}\text{C}$.
If the environment temperature exceeds the allowed limit, the projector will stop displaying content and shut itself down. The projector will resume working when the temperature falls back within the operating range.
- Do not turn off the device if the temperature drops below -15° .
- The projector's laser unit produces an extensive amount of excessive heat, therefore there are large ventilation openings on the bottom of the machine, AIR INTAKE and AIR EXHAUST. Always ensure that the ventilation openings are not blocked by any objects, which could cause your projector to easily overheat.
- Your LAZR projector can be operated outdoors as long as it is always positioned horizontally within the allowed angles (see page 6).
- Always use sufficient ground protection attached to the grounding screw to prevent electric shock risk!
- Do not cover the device while it is running as it may cause it to overheat.
- ALWAYS REMOVE THE PROTECTIVE LENS CAP from the lens before you turn your projector ON!
- Do not use the device when it is damaged and do not try to dismantle it.
There is a risk of electric shock!
- Do not use any damaged cables!
- The projector is equipped with IP67 plug, ensure that you use a compatible plug or any power connector suitable for outdoor use.
- The projector is a heavy machine, therefore always install it carefully and ensure it is securely fastened. Avoid installing the device in places where falling may cause injury!
- Ensure there are no objects closer than 1 m in the projector light cone.
Strong light might cause fire!
- Aiming the projector towards the sun may cause fire, or damage DLP unit.
- Do not look into the projector lens while the lamp is on! The intense light beam may damage your eyes.
- Install the projector carefully so you do not blind passers-by with strong light!
- Do not step on the projector or place any objects on top of it. Besides probable physical damage to the projector, doing so may result in accidents or possible injury.
- Do not install near any heat sources such as radiators, heat registers, stoves, or other devices (including amplifiers) that produce heat.



LASER Safety Instructions

- As with any bright light source, do not stare into the beam, RG2 IEC 62471-5:2015.



- This symbol indicates that there is a potential hazard of eye exposure to laser radiation unless the instructions are closely followed.



This Laser Product is designated as Class 3R during all procedures of operation.
LASER LIGHT - AVOID DIRECT EYE EXPOSURE.
Do not point laser or allow laser light to be directed or reflected toward other people or reflective objects.
Direct or scattered light can be hazardous to eyes and skin.



There is a potential hazard of eye exposure to laser radiation if the included instructions are not followed.
Caution – use of controls or adjustments or performance of procedures other than those specified herein may result in hazardous radiation exposure.

Laser parameters:

- Wavelength: 450nm - 460nm (Blue)
- Mode of operation: Pulsed, due to frame rate
- Pulse width: 1.34ms
- Pulse repetition rate: 120Hz
- Maximum laser energy: 0.698mJ
- Total internal power: >100w
- Apparent source size: >10mm, at lens stop
- Divergence: >100 mili Radian



Opening the Device



It is forbidden to remove the covers inside the device. There is a risk of electric shock!



Attention! Metal parts inside the device, they may be hot due to the function!



Attention! Inside the device are fans.



Attention! Inside the device are a movable optics cover.

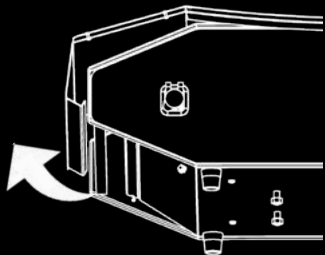

Opening the cover:

Put your hands into the air vent in the left corner, closest to you, and with your fingers pull the roof cover, until you feel the cover coming out. Then continue with the same movement in the middle of the air vent and the same in the furthest corner. Now you can lift the roof up, but be careful because there are no hinges, so you must hold it with both hands.

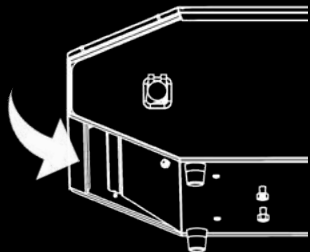

Closing the cover:

Hook one side of the roof on the bracket in front of the air vent and then slowly lower the other side back into position and again using both hands push the corner over the bracket until the whole side is in the correct position. You might need to use a little bit more pressure. Standing behind or in front of the projector push on both sides of the projector with one hand on each side, placing your fingers into the air vent. The roof should be placed tightly with no gaps.



Safety Instructions for inserting the AV / computer unit

- Take extra care when installing your computer to avoid damaging wiring and covers.
- It is your own responsibility to install your own computer in to the device. If the device is damaged due to incorrect connection, no claim can be accepted.
- Installation of the computer inside of device, should be supervised by an expert, who will also verify the correct connection.
- Always open the device and install it only in good weather or indoors. After removing the cover, the device is not protected against moisture and water!
- It is forbidden to connect units that are damaged or could overload the power supply!
- To power your electronics, you can use inside the device:
 - USB power supply **5V DC 3A max.**
 - DC power supply **12V DC 10A max.**
- START pulse for your AV system is on the two-pin connector „PC“



Troubleshooting

In case a projector malfunction occurs, try the following steps:

- Turn Off and Turn On
Disconnect and reconnect the power connector.
- Delete all scheduler tasks:
Hold down the power button until the LED indicator turns turquoise, then release the power button.



Support

support@lm3x.com



Recommended AV computers and units

- maximum module dimensions 170x170x40mm

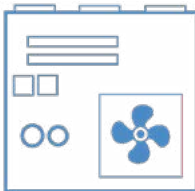

mini ITX PC format motherboards



Device Description - inside

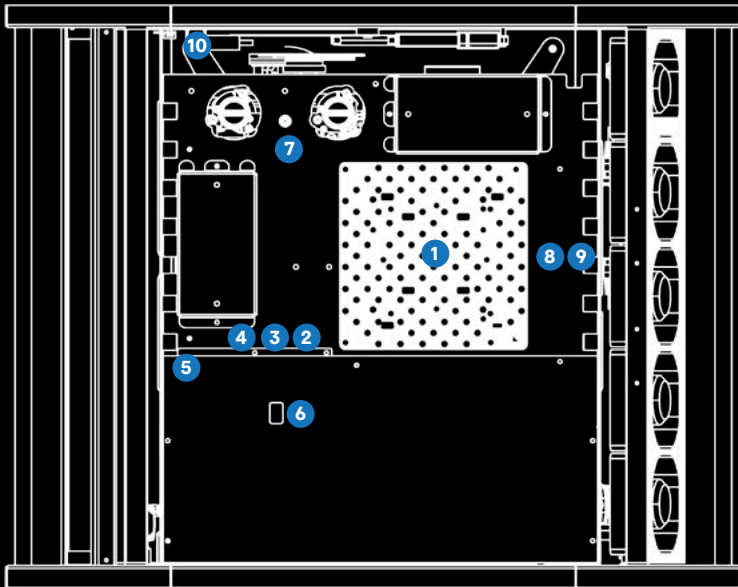

- 1 Attachment place for your unit
- 2 USB Power connector
- 3 DC 12V connector
- 4 PC "start pulse" connector
- 5 USB LUMIduino electronic
- 6 FAN / HEATER set
- 7 USB IN / OUT connection
- 8 Internal HDMI cable to projector
- 9 LAN / HDBaseT / PJLink cable
- 10 Space for WiFi USB module



Optical settings

Inside the device you will find controls to optimize the projection. Important! Take extra care, laser radiation is present. Follow the instructions on page 10.

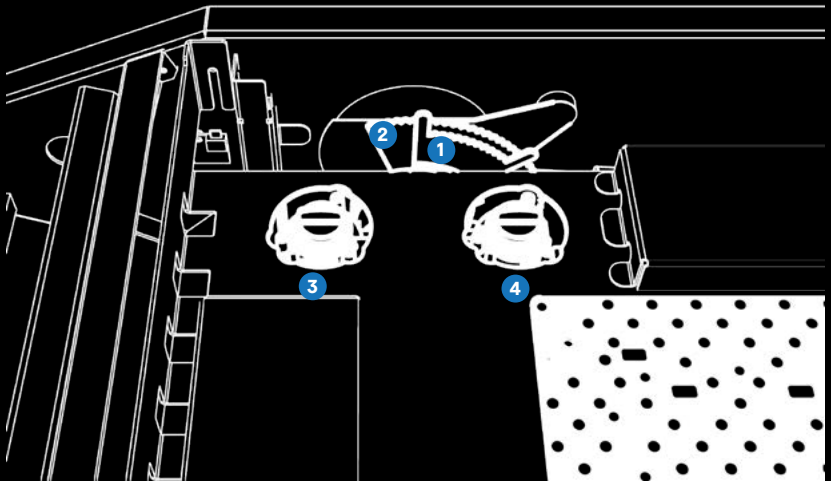

- 1 ZOOM
- 2 FOCUS
- 3 Vertical pixel shift
- 4 Horizontal pixel shift



Power Management

- The projector is equipped with an automatic dehumidification system to prevent any damage caused by moisture.
- Once installed outdoors, it is important to keep the projector ON and connected to a reliable permanent power source!
- If a blackout occurs, the projector will wake up and continue playing the show automatically once the power source has been restored.



LED Indications

LUMI Logo Indication

- Shining - connected to electricity.
- Not shining - disconnected from electricity.

Color LED Status

- Green shining - the projector is turned on
- Green pulsing - waiting for the projector lamp to heat up / cooldown
- Turquoise - delete all scheduler tasks
- Red shining - the lens cover cannot be opened
- Red pulsing - projector error
- Purple shining - fans blocked
- Blue pulsing - thermometers not found
- Blue shining - low temperature - projector heating
- Yellow shining - temperature too warm - wait for cooldown
- Yellow pulsing - the projector has overheated
- White pulsing - RTC error
- White shining - the time is not set



Connectors Matching

To maintain functional IP protection, use only with these Neutrik® connectors:

POWER connector:

NAC3FX-W-TOP (1 pcs. included)

LAN connector:

NE8MC6-MO

HDMI connector:

NKHDMI-*

USB connector:

NKUSB-*



Maintenance

Laser

Laser lifespan is 20,000 hours. At the end of lifetime, service must be carried out by the manufacturer.

Lens

Dirt on the projector lens may affect the light show quality. Clean with a regular soft glass cleaning cloth. Use a screwdriver to remove the lens for cleaning.

Air Filter

The LAZR projector is equipped with an interchangeable air filter. We recommend replacing the air filter every half year. In dusty environment replace the filter more often.

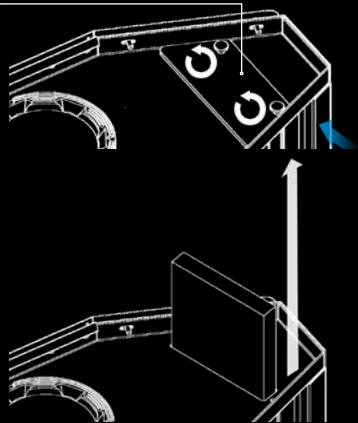



Declaration of Conformity

Hereby declare that:

Product: OUTDOOR PROJECTOR
Machine Type: LAZR



Is compliant with the essential requirements and any other relevant provisions of the following EC directives, and that all the necessary steps have been taken and are in force to assure that the production units of the same product will continue to comply with the above specified requirements.

ELECTRICAL SAFETY TEST

The following regulations have been used:
EN 62368-1:2014 + AC:2015-05 + A11:2017

ELECTROMAGNETIC COMPATIBILITY TEST

The following regulations have been used:

EN 55024:2010
EN 55032:2015
EN 61000-3-2:2014
EN 61000-3-3:2013
EN 61000-4-2:2008
EN 61000-4-3:2006 +A1:2007 +A2:2010
EN 61000-4-4:2012
EN 61000-4-5:2014
EN 61000-4-6:2014
EN 61000-4-11:2004



Declaration of RoHS2 Compliance

Product: OUTDOOR PROJECTOR
Machine Type: LAZR



This product has been designed and manufactured in compliance with Directive 2011/65/EU of the European Parliament and the Council on restriction of the use of certain hazardous substances in electrical and electronic equipment (RoHS2 Directive) and is deemed to comply with the maximum concentration values issued by the European Technical Adaptation Committee (TAC) as shown below:

Substance	Proposed Maximum Concentration	Actual Concentration
Lead (Pb)	0.1%	< 0.1%
Mercury (Hg)	0.1%	< 0.1%
Cadmium (Cd)	0.01%	< 0.01%
Hexavalent Chromium (Cr6+)	0.1%	< 0.1%
Polybrominated biphenyls (PBB)	0.1%	< 0.1%
Polybrominated diphenyl ethers (PBDE)	0.1%	< 0.1%

Certain components of products as stated above are exempted under the Annex III of the RoHS2 Directives as noted below:

Examples of exempted components are:

1. Mercury in cold cathode fluorescent lamps and external electrode fluorescent lamps (CCFL and EEFL) for special purposes not exceeding (per lamp):
 - (1) Short length (≤ 500 mm): maximum 3.5 mg per lamp.
 - (2) Medium length (> 500 mm and $\leq 1,500$ mm): maximum 5 mg per lamp.
 - (3) Long length ($> 1,500$ mm): maximum 13 mg per lamp.
2. Lead in glass of cathode ray tubes.
3. Lead in glass of fluorescent tubes not exceeding 0.2% by weight.
4. Lead as an alloying element in aluminium containing up to 0.4% lead by weight.
5. Copper alloy containing up to 4% lead by weight.
6. Lead in high melting temperature type solders (i.e. lead-based alloys containing 85% by weight or more lead).
7. Electrical and electronic components containing lead in a glass or ceramic other than dielectric ceramic in capacitors, e.g. piezoelectronic devices, or in a glass or ceramic matrix compound.

Notes:

Notes:

LM3X

info@lm3x.com

www.lm3x.com

© 2021